

Global Leadership in Heavy  
Duty Heat Transfer  
Components and Systems

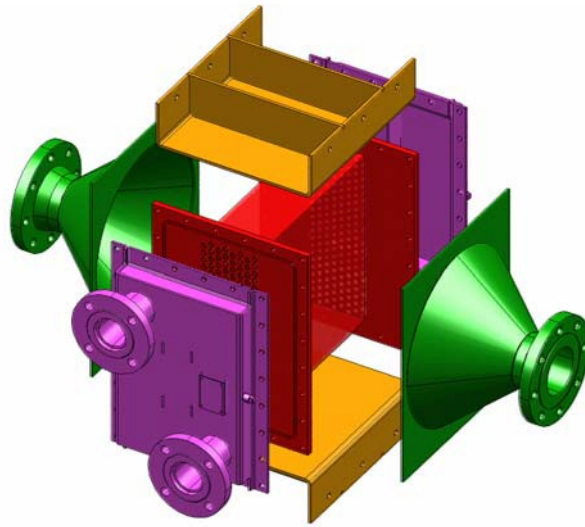

Remote Mounted  
Charge Air Cooler

Young Touchstone is currently releasing a new remote "CAC" series air to water charge air coolers. Designed for use with 150 through 2500 kW remote radiator installations, the new "CAC" series, provides a complete remote cooling solution for charge air cooled engines. All designs utilize Young Touchstone's patented *ABT* high temperature core capable of operating temperatures up to 550°F and the field proven Mechanical Bond Core Header design for superior durability and leak proof operation.

All Young Touchstone remote "CAC" charge air coolers are sized, matched and supplied with an appropriate mating horizontal or vertical remote DS radiator to assure guaranteed jacket water and charge air cooling to engine manufacturer specifications.

Design Features Include:

- ” Durable Round Tube — Copper Fin Charge Air Core
- ” Durable Mechanical Bond Tube to Header Joint Construction
- ” Reliable O-Ring Tank Seals eliminate tank leaks due to gasket failure.
- ” Heavy Gauge Structural Framework utilizes Finite Element Analysis (FEA) and Testing to guarantee structural integrity
- ” Welded Air Side Manifolds supplied with Mounting Flange to mate with engine CAC connections
- ” Air Side Operating Designs to 45 psig, 550°F; coolant side 35 psig
- ” Radiator Sized to Specific Application Requirements to assure compliance to engine manufacturer's specifications
- ” Two Year Warranty Standard

Young Touchstone's Remote CAC designs are available in 1.5 through 8 square foot configurations designed for mounting on the generator set sub-base in place of the normal gen-set mounted radiator.