

## **OCH Air Cooled Oil Coolers**

OCH Air Cooled Oil Coolers have been developed by Young Touchstone as a result of over 50 years experience in the design and manufacturer of fluid cooling equipment. Within the fluid power market, many leading industries require an economic cooler, universally adaptable to an increasing variety of oil cooling applications. Young Touchstone, combining design skill with high standards for construction and performance, has produced this efficient line, providing ample cooling at minimum cost to the customer.

Young Touchstone OCH Oil Coolers are designed for cooling lubricating oil and hydraulic fluids in applications involving bearings, reduction gearing, torque converters, marine transmissions, transformers, internal combustion engines, machine tools and processing equipment. They have an efficient heat transfer core made of steel tubes, aluminum fins and tubular steel manifolds.

OCH have the advantage of providing ample cooling requirements in areas where water is costly or unavailable or when water circuit piping is undesirable and inconvenient. Air cooling also eliminates the necessity for expensive water antifreeze solutions required to keep water coolants from freezing during the winter. These coolers do double duty in cold climates by recirculating the waste heat absorbed in the cooling process to heat the surrounding room interior.

There are six standard OCH Oil Coolers with a top thermal capacity of **100 hp** 76 kw available in single and three phase configuration.



Fig. 7

Exclusive patented Young Touchstone Turbulators inserted in each tube improve heat transfer more than 100% by eliminating laminar oil flow.

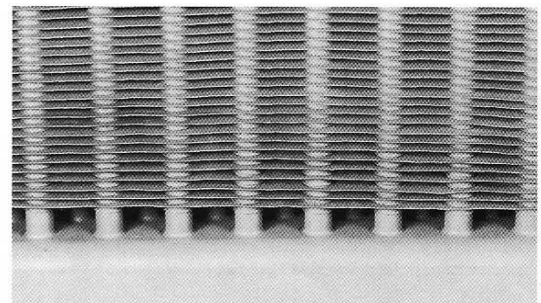

Fig. 8

Unique Young Touchstone-pioneered, automatic induction, high temperature, brazing method insures permanent bond and positive contact of tube to manifold, eliminating leaks and providing maximum service life.

## **OCH Construction Features**

**Fan Shroud**—Insures maximum efficiency by channeling ample air entry.

**Fan Guard**—Welded steel, zinc plated guard provides adequate protection in accordance with OSHA.

**Fan**—Aerodynamically designed for maximum air delivery and quiet operation. Static balance insures vibration-free performance.

**Motor**—Totally enclosed type insures safe, clean, maintenance-free operation—selected especially for use on oil coolers.

**Motor Bracket**—Shelf type in design—provides secure motor base with minimum air restriction.

**Connections**—Inlet and outlet oil connections with male dry-seal threads prevent leaks, allow efficient fluid flow with minimum pressure drop. Rear location simplifies piping assembly. Coolers are designed for service either as one pass or two pass; proper connections to be made by customers. Field modifications are possible to satisfy changing flow requirements.

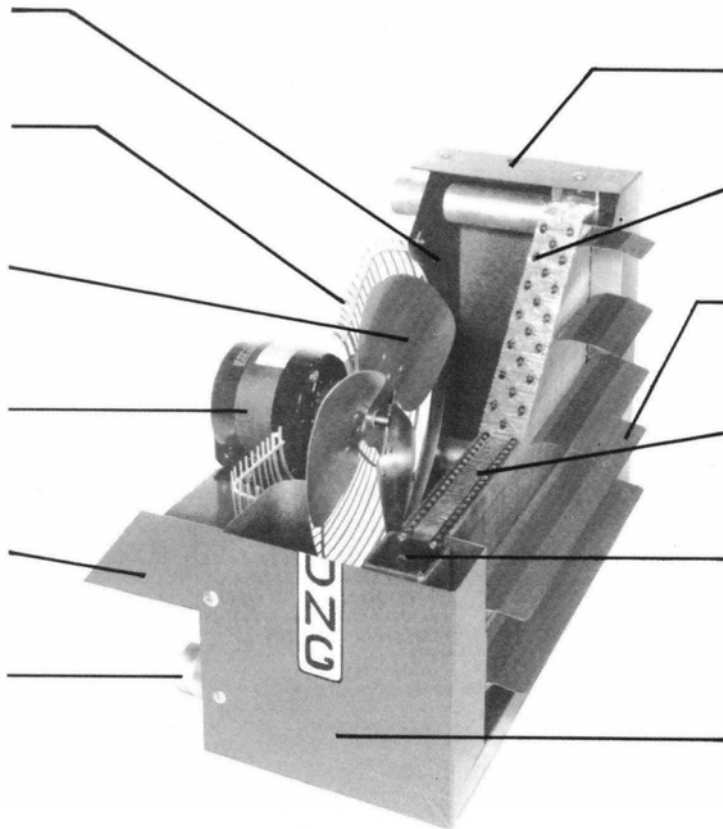

**Mounting Holes**—Two top and two bottom— $\frac{1}{2}$ -13 UNC tappings.

**Turbulators**—Patented by Young Touchstone increase heat transfer 100%.

**Louvers**—Air deflectors permit controlled air discharge.

**Core**—Aluminum fins mechanically bonded to high pressure round steel tubes provide great strength and maximum heat transfer rate.

**Manifolds**—Tubular steel, automatic induction, high temperature brazed to the tubes, provide leak-proof performance.

**Cabinet**—Attractively designed—stamped from heavy gauge steel.

Jackson, Tennessee  
Corporate Office  
200 Smith Lane  
Jackson, TN 38308

Lexington, Tennessee  
Production Facility  
1000 Young Drive  
Lexington, TN 38351

Young Touchstone  
Sales Office  
7270 S 13th St, Ste 201  
Oak Creek, WI 53154

PH: 731-424-5045  
FX: 731-424-4625  
TF: 800-238-8230

PH: 731-968-3617  
FX: 731-967-7752  
TF: 800-238-8230

PH: 414-768-7420  
FX: 414-762-0632  
TF: 800-349-0275